

IF IN DOUBT ASK

OPTIONS:

- 1: FOR EXPOSED INLET OR OUTLET SAFETY GUARDS ARE REQUIRED.
- 2: 1 OFF 1" BSP (OR NPT) BODY VENT ON NON-DRIVE SIDE.
- 3: 1/8" BSP (OR (NPT) AIR PURGED END COVER GLANDS.
- 4: ROTOSPEED SENSOR AS INDICATED.
- 5: INSPECTION DOOR ON NON-DRIVE SIDE (NOT SHOWN) WITH 95x84mm APERTURE.

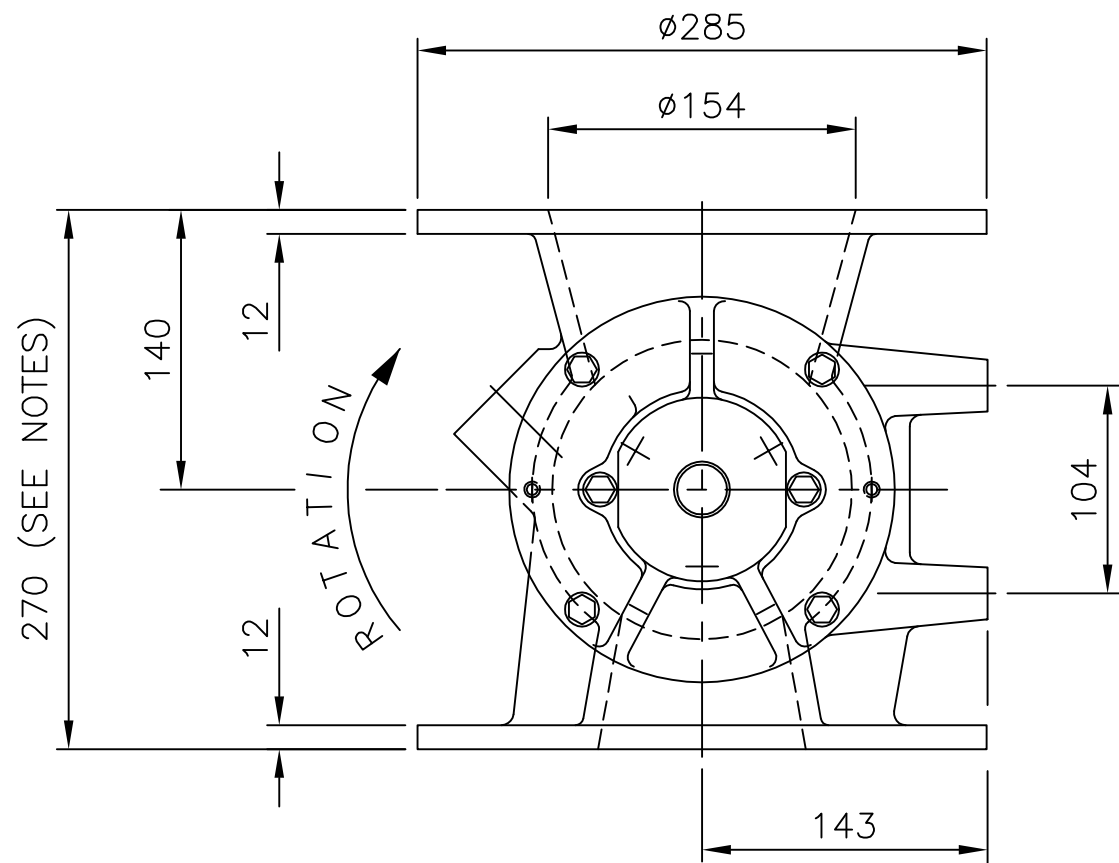
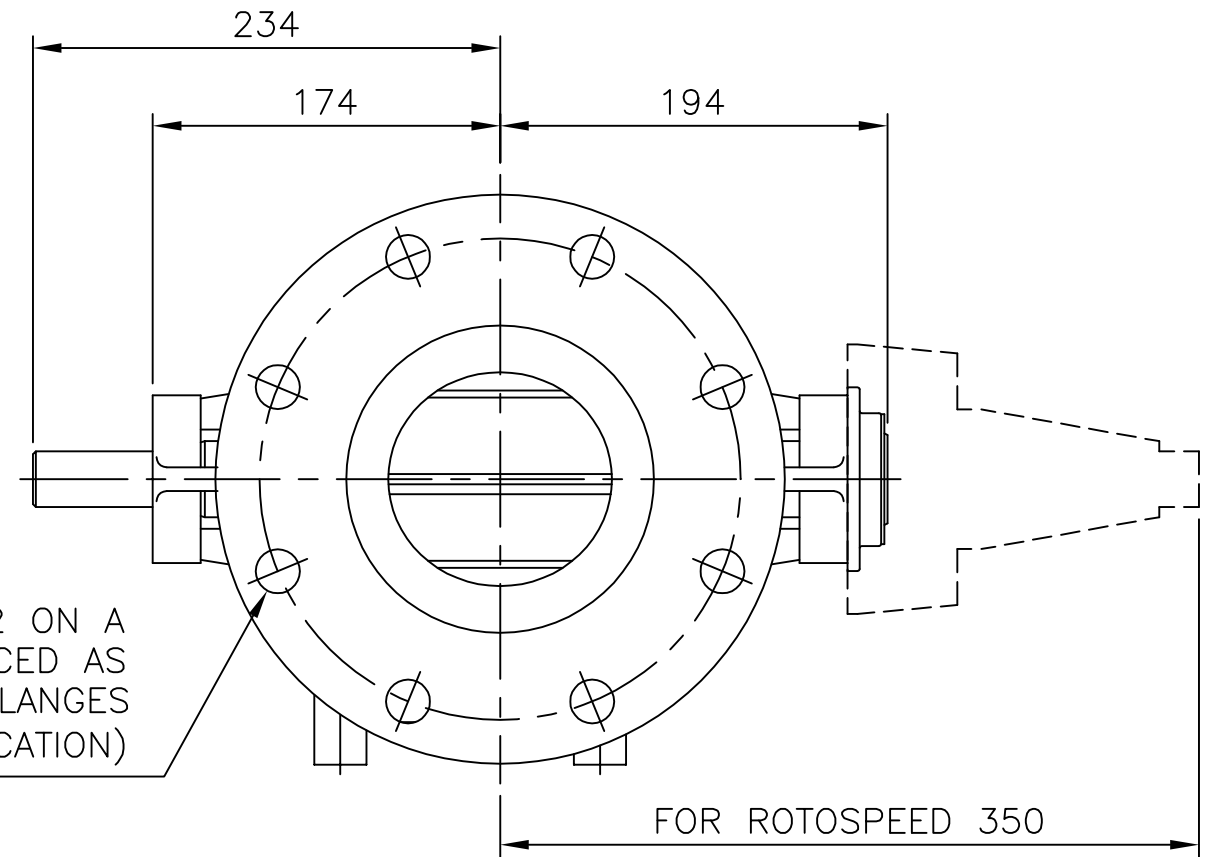

KEYWAY TO SUIT
8mm WIDE x
7mm DEEP KEY

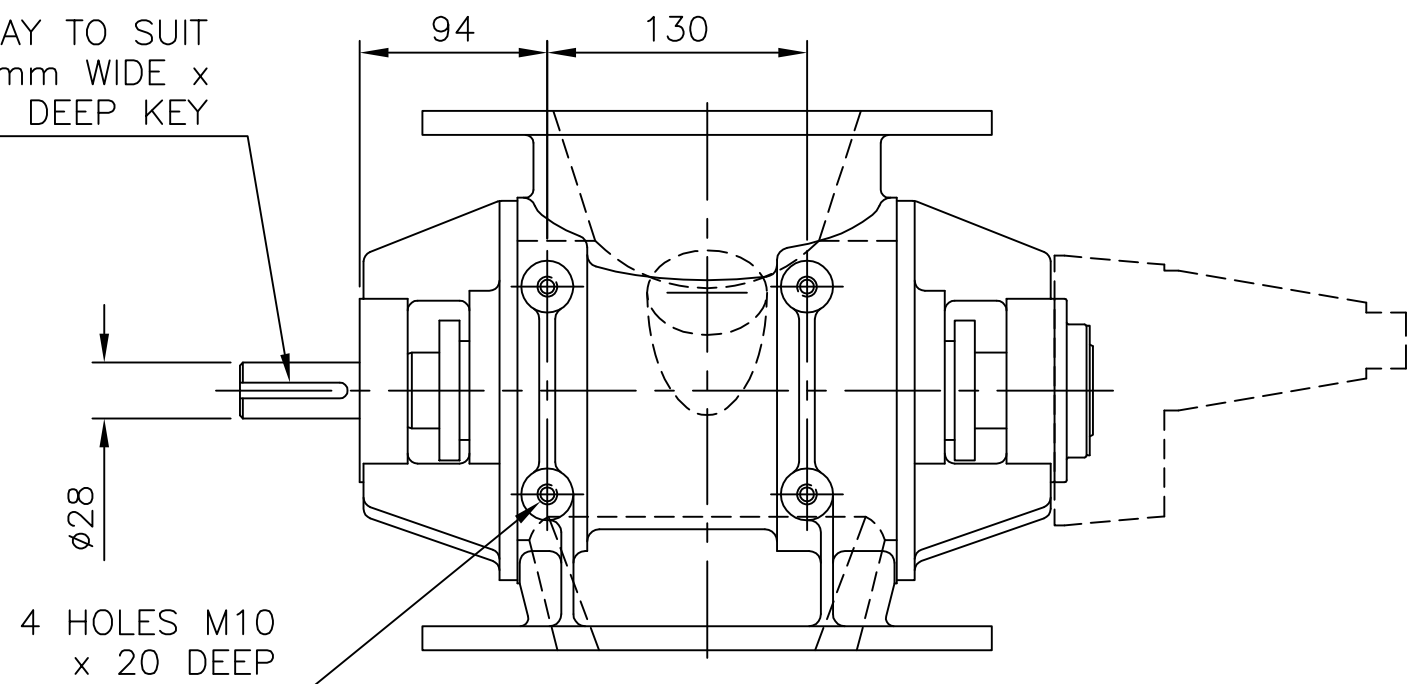

ITEM	PART No.	QTY	DESCRIPTION	MATL.	DWG REF
CLIENT			TITLE BARESHAFT ARRANGEMENT		
STANDARD			150mm ROUND ROTARY VALVE		
SCALE N.T.S.			DRAWING No.		
			11643		
DRAWN			CHECKED	APPROVED	ISSUE C
21/3/94					

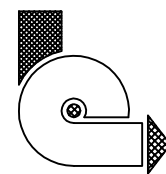

ROTOLOK LTD

everything under control . . .

1 MILLENNIUM PLACE,
TIVERTON BUSINESS PARK,
TIVERTON, DEVON, EX16 6SB.
Tel: 01884 232232

This drawing is the property of ROTOLOK LTD and is loaned subject to the condition that it shall not be reproduced, copied, loaned or submitted to others without our consent.

C OPTIONS & ROTOSPEED ADDED (1442)

B MOTOR BOSS LENGTH WAS 109

AMENDMENTS